

| | |
|-------------|--|
| category | soundproofing |
| description | RFT50 high performance resilient tape |
| part code | NE360RT |



Custom Audio Designs



NE360RT RFT50 RESILIENT TAPE is an open cell natural rubber with excellent loading and recovery properties. It is mainly used as a superior material for fixing to joist tops before floating tongued and grooved floorboards or chipboard.

Advantages

- CFC- and HFC-free
- Recyclable



A micro-fibre mesh offers an excellent surface for the application of adhesive. A predominantly polyester weave adds strength to the polymer base and is a stronger, tougher, durable material.

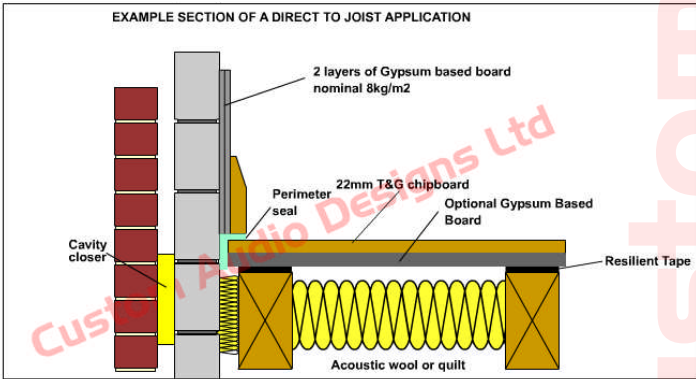
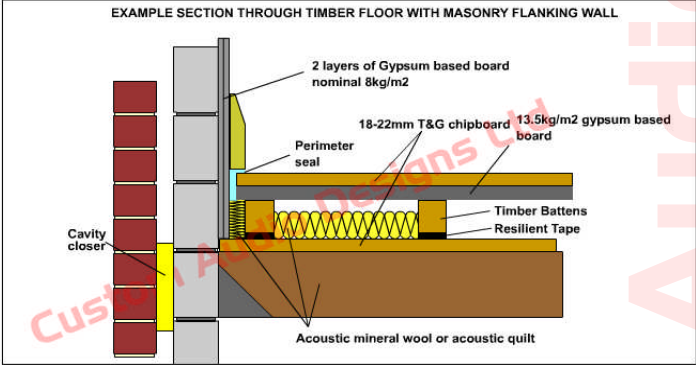
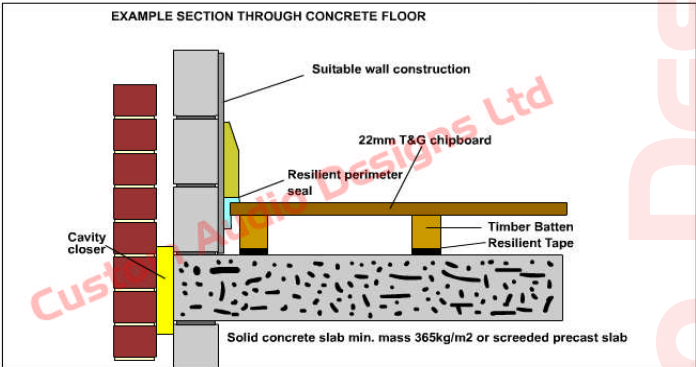
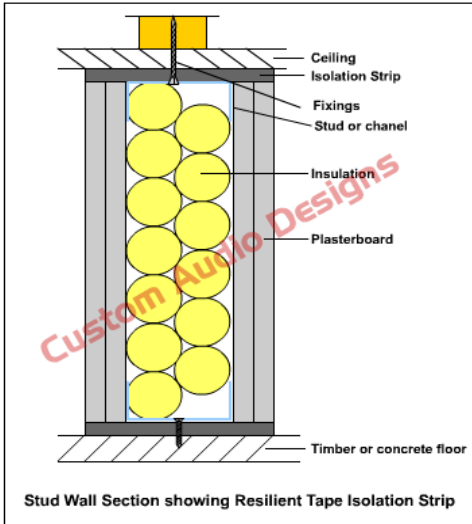

Technical Specification

| | | |
|--|--|---------------------------------------|
| Product | NE360RT | RFT50 High Performance Resilient Tape |
| Colour | Black | |
| Polymer | Natural rubber c/w micro-fibre surface | |
| Compression deflection: at 25% | Medium | 5-10 PSI |
| Compression set: 50% deflection @ 70°C | 15% maximum | |
| Accelerated ageing - 100% change in compression deflection @ 70% | ±20% | |
| Temperature range | -40°C to +80°C | |
| Density average kg/m ³ | 390 ±10% | |
| Modulus | 280kpa | |
| Elongation | 250% | |

All information contained in these details is given in good faith but without warranty. Custom Audio Designs reserves the right to alter the specifications of any product without notice.

© 2008 Custom Audio Designs Limited: No part of this information sheet may be reproduced in any form without the express written permission of Custom Audio Designs Limited. Check for later versions.